



**VACUUM CONTROL
SPI-MODULE™
INSTRUCTION MANUAL**

SPI Supplies Division of **STRUCTURE PROBE, iNC.**

569 East Gay Street, P.O. 656, West Chester, PA 19381-0656 (610) 436 5400 Fax: (610) 436-5755

E-Mail SPI3SPI@2SPI.com Website - <http://www.2spi.com>

Canada: Box 187, Postal Station "T", Toronto, Ontario, M6B 4A1 Canada (416) 787-9193 800-668-2028 Fax (416) 781-0249
SPI Supplies is a registered trademark of Structure Probe, Inc.



Structure Probe, Inc. / SPI Supplies
Street address for UPS, FedEx, DHL, other couriers, trucks
569 East Gay Street
West Chester, PA 19380

Mailing address P.O. Box 656 West Chester,
PA 19381-0656 USA

Toll-free from USA/Canada: 1-(800)-2424-SPI
Phone: 1-(610)-436-5400
FAX: 1-(610)-436-5755
E-mail: spi3spi@2spi.com

For further information regarding any of the other products designed and manufactured by SPI Supplies, contact your local representative or directly to SPI Supplies at the address above, or visit www.2spi.com

- Carbon and Sputter coaters
- Plasma Reactor for ashing and etching
- High Vacuum Bench Top Evaporators
- Critical Point Dryers
- Electron Microscopy Supplies, Consumables and Accessories



Warranty

The SPI Supplies unit you have purchased is guaranteed to be free of defects in workmanship on the day of shipment. This warranty covers parts and labor for a period of one year, excluding shipping charges or consumables. Breakage of glassware is specifically excluded from this warranty.

Proper use of your unit, according to the operation manual, should result in trouble-free operation. Any improper use of the SPI Supplies unit through modifications or unreasonable operating procedures will void this warranty.

DISCLAIMER

SPI Supplies Plasma-Prep III is designed for simplicity of installation and operation. This manual provides full and complete information in both of these areas. SPI Supplies therefore assumes no liability or responsibility of any kind for damage or injury resulting from incorrect installation or operation of the machine.

If any questions arise, call SPI Supplies from the USA/Canada 1-800-2424-SPI or 1-610-436-5400 for assistance. For all other countries, contact our nearest agent or SPI Supplies directly. A listing of our agents may be found on our website at:

<http://www.2spi.com/info/agents/>

TABLE OF CONTENTS

A. SERVICES REQUIRED.....	4
B. GENERAL DESCRIPTION.....	4
C. INSTALLATION.....	5
D. TEST PROCEDURE.....	6
E. SPARE PARTS.....	7

A. SERVICES REQUIRED

The following services are either required or optional for the operation of the SPI-MODULE CONTROL unit :

1. **Power:** Check the voltage label near the main power cord to ensure that the equipment has been supplied for the correct laboratory voltage and frequency.

OPTIONAL

2. **ARGON GAS (Industrial Grade) :** A commercial cylinder fitted with a two stage regulator so that a pressure of around 5 psi can be obtained.

3. **WATER:** The base plate of the work chamber can be water-cooled if required.

B. GENERAL DESCRIPTION

The SPI-MODULE CONTROL unit has been designed as the basis of a range of SEM sample coating instruments. The main cabinet contains all the necessary hardware to control and monitor vacuum pressure within the work chamber.

The front panel arrangement is shown in Figure 1. The meter measures chamber pressure both in millibars and millitorr units. The main power switch controls the power to the instrument and also to the vacuum pump when connected to the receptacle provided on the rear panel see fig 2. The needle valve controls the leak of the argon into the work chamber which, in turn will control the plasma current if the instrument is used in a sputtering mode.

The back panel (figure 2) houses all the service connections. The main power cord enters the rear of the instrument and the instrument is protected by a 1"x 1-1/4" 10 amp glass fuse. The vacuum pump is electrically connected to the receptacle on the rear panel and also to the 1/2" brass tube extending out the rear by the shortest convenient length of rubber hose supplied. Argon gas is fed from the cylinder regulator head to the inlet fitting. Cool water may be circulated through the chamber base plate via the water fittings. The design of the base plate also acts as a baffle to condense any back streamed rotary pump oil. The vacuum interlocked power outlet is fused with a 1"x 1-1/4" 10 amp glass fuse, and is used to power the SPI-MODULE SPUTTER COATER or the SPI-MODULE CARBON COATER.

The SPI-MODULE CONTROL unit can also house internally the SPI-MODULE QUARTZ CRYSTAL THICKNESS MONITOR. Fitting of this unit is described in a separate handbook.

C. INSTALLATION

1. The unit is supplied with the following parts packed separately:

- (I) SPI-MODULE CONTROL UNIT
- (II) PYREX CHAMBER 4" X 5"
- (III) CENTRAL STAGE AND SPECIMEN HOLDER
- (IV) 5' RUBBER VACUUM HOSE
- (V) OPERATING MANUAL
- (VI) 2 STAINLESS STEEL HOSE CLAMPS

To complete a system the following SPI-MODULES may be supplied either or

- (I) SPI-MODULE SPUTTER COATER (with sputter head containing a 3 mil gold cathode and cable)
- (II) SPI-MODULE CARBON COATER (with carbon fiber head and cable and 1 meter of carbon fiber)
- (III) An optional carbon rod head is available.

2. Unpack the SPI-MODULE CONTROL unit and connect the vacuum pump inlet port to the brass tube with the shortest length of vacuum hose possible. Connect the pump electrical cord to the pump receptacle on the rear of the unit. Check that the pump is filled with oil and is ready for use in accordance with the manufactures instructions provided.

3. Connect the outlet of the argon cylinder regulator head to the gas inlet fitting on the rear panel see fig 2 and set to 5 psi.

4. The base plate of the work chamber can be water cooled if coating of very delicate specimens is attempted. The cooling water can be connected to the two quick disconnects on the rear panel (see fig 2) 1/8" o.d. nylon tubing is necessary (not supplied).

5. Place the glasswork chamber onto the base plate and locate it into the "O" ring grove. Fit the sputter or carbon fibber head whichever is appropriate for the work to be done onto the top of the glass chamber. At this stage do not make any electrical connection to this head.

6. Plug the power cord into a laboratory receptacle of the correct voltage. The unit is now ready for use.

D. TEST PROCEDURE

Having connected all electrical cables and services the unit can now be test run. Check that the gas leak valve is fully closed (clockwise) and that the argon regulator is open and the pressure is set at about 5 psi .

WARNING: OVER TIGHTENING THE VALVE MAY CAUSE DAMAGE TO THE VALVE.

1. Switch on the power. The vacuum pump will start immediately and after 10 - 15 seconds (depending on the pump size) the vacuum gauge will register the fall in pressure inside the chamber. The unit should be left running until the gauge reads in the range of 60 - 80 millitorr. This indicates there are no major leaks in the system.
2. Open the gas leak valve (counterclockwise) and observe the rate of rise of the pressure relative to the position of the leak valve.
3. Finally, close the gas valve and, turn off the 'POWER' switch and vent the chamber with the vent valve on the top of the head.

This completes the test run of the SPI-MODULE CONTROL unit and the various evaporation controls; modules can now be connected in accordance with their own manuals.

E. SPARE PARTS LIST FOR VACUUM CONTROL BASE MODULE SPI # 11425-AB

<u>PART NO.</u>	<u>DESCRIPTION</u>
VC13/21	10A Fuse 1/4"x 1-1/4" Glass (Slo Blo)
V10H/1	Metal Hose 40 Inches Long KF16 Flange
VM30/1	Flange Clamp KF16
11005H-AB	Rubber Vacuum Hose (specify length)
V7/1	Moducel Vacuum Sensor & Control
V8/1	Meter Vacuum Gauge
VM31/1	Needle Valve
11425PS-AB	Power Supply
11446-AB	Pyrex Chamber
11458-AB	Set of 2 O-rings for Pyrex Chamber
11460-AB	Set of 3 O-rings for Vacuum Base
V4/2	Relay 120 volt
V4HV/2	Relay 240 volt

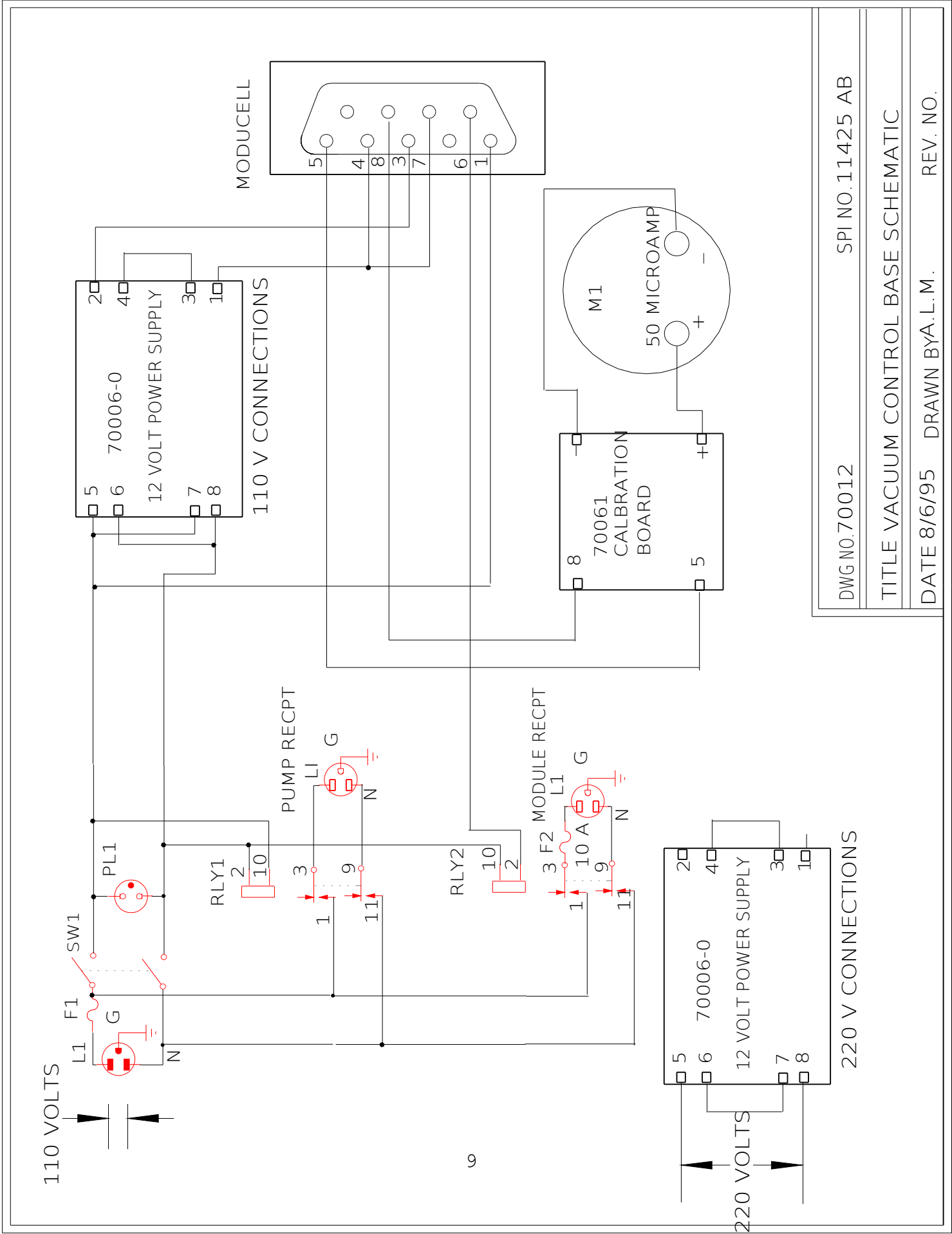

DWG NO. 70012

SPI NO. 11425 AB

TITLE VACUUM CONTROL BASE SCHEMATIC

DATE 8/6/95 DRAWN BY A. L. M. REV. NO.

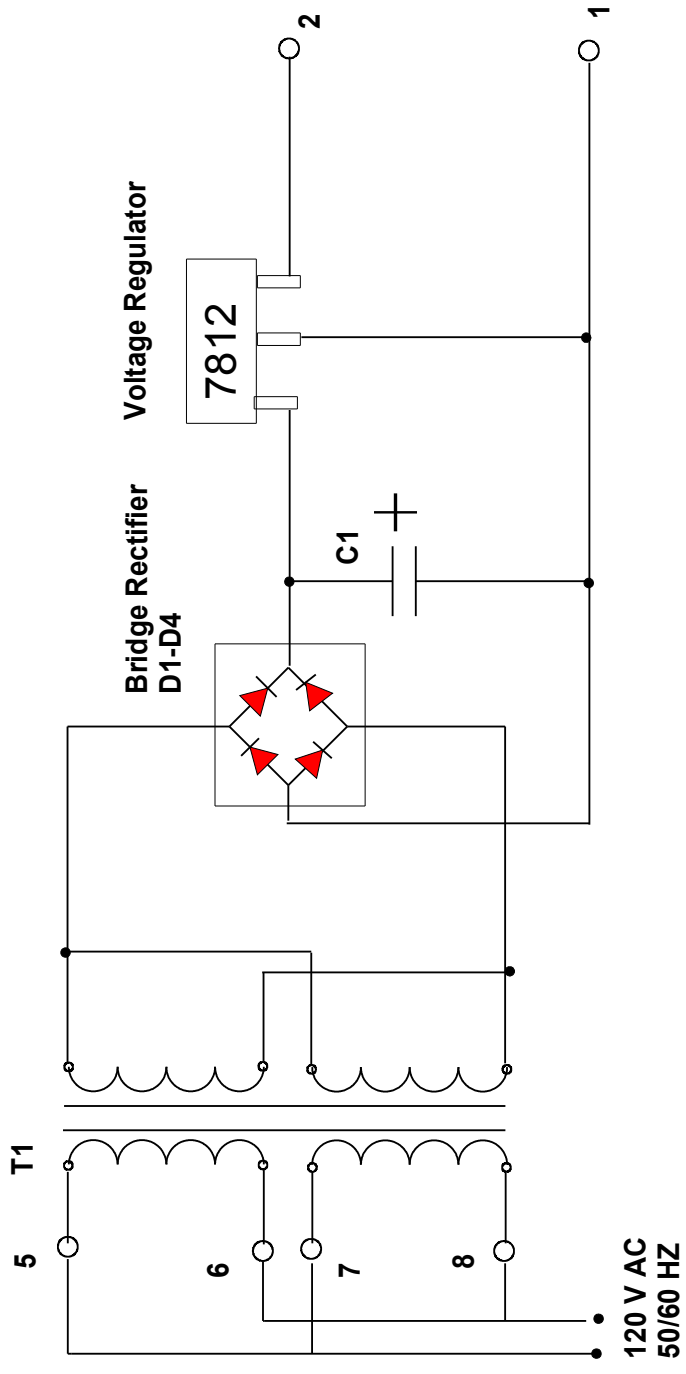

DWG.NO POWER SUPPLY

DESC. 12 VOLT DC SUPPLY

DATE 4/21/99 DRAWN BY

REV. NO.

Function/Service Chart for Vacuum Base

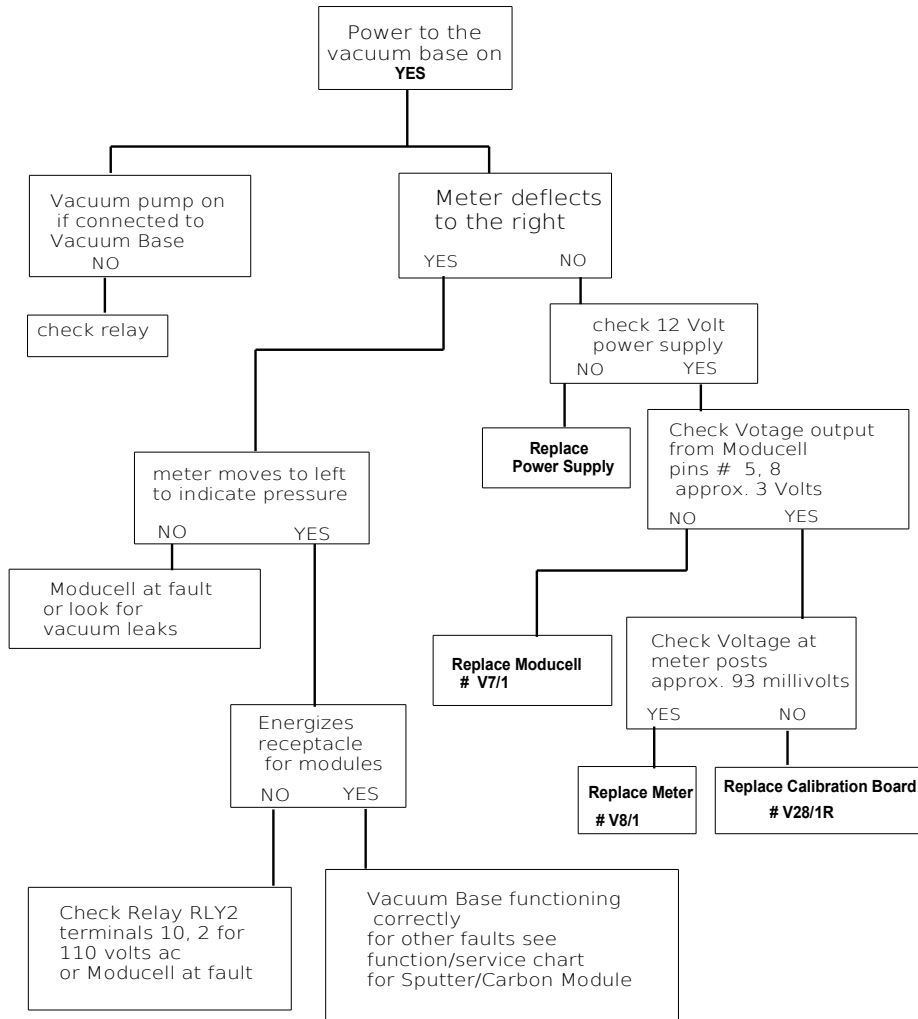

7/7/2011

for questions contact SPI Supplies
 Tele: 610 436 5400 2spi@2spi.com