



Structure Probe, Inc. / SPI Supplies

Street address for UPS, FedEx, DHL, other couriers, trucks

569 East Gay Street

West Chester, PA 19380

Mailing address P.O. Box 656 West Chester,

PA 19381-0656 USA

Toll-free from USA/Canada: 1-(800)-2424-SPI

Phone: 1-(610)-436-5400

FAX: 1-(610)-436-5755

E-mail: spi3spi@2spi.com

For further information regarding any of the other products designed and manufactured by SPI Supplies, contact your local representative or directly to SPI Supplies at the address above, or visit **www.2spi.com**

- Carbon and Sputter coaters
- Plasma Reactor for ashing and etching
- High Vacuum Bench Top Evaporators
- Critical Point Dryers
- Electron Microscopy Supplies, Consumables and Accessories



Warranty

The SPI Supplies unit you have purchased is guaranteed to be free of defects in workmanship on the day of shipment. This warranty covers parts and labor for a period of one year, excluding shipping charges or consumables. Breakage of glassware is specifically excluded from this warranty.

Proper use of your unit, according to the operation manual, should result in trouble-free operation. Any improper use of the SPI Supplies unit through modifications or unreasonable operating procedures will void this warranty.

DISCLAIMER

SPI Supplies Plasma-Prep III is designed for simplicity of installation and operation. This manual provides full and complete information in both of these areas. SPI Supplies therefore assumes no liability or responsibility of any kind for damage or injury resulting from incorrect installation or operation of the machine.

If any questions arise, call SPI Supplies from the USA/Canada 1-800-2424-SPI or 1-610-436-5400 for assistance. For all other countries, contact our nearest agent or SPI Supplies directly. A listing of our agents may be found on our website at:

<http://www.2spi.com/info/agents/>

Carbon Module Function / Service Chart

With fiber head

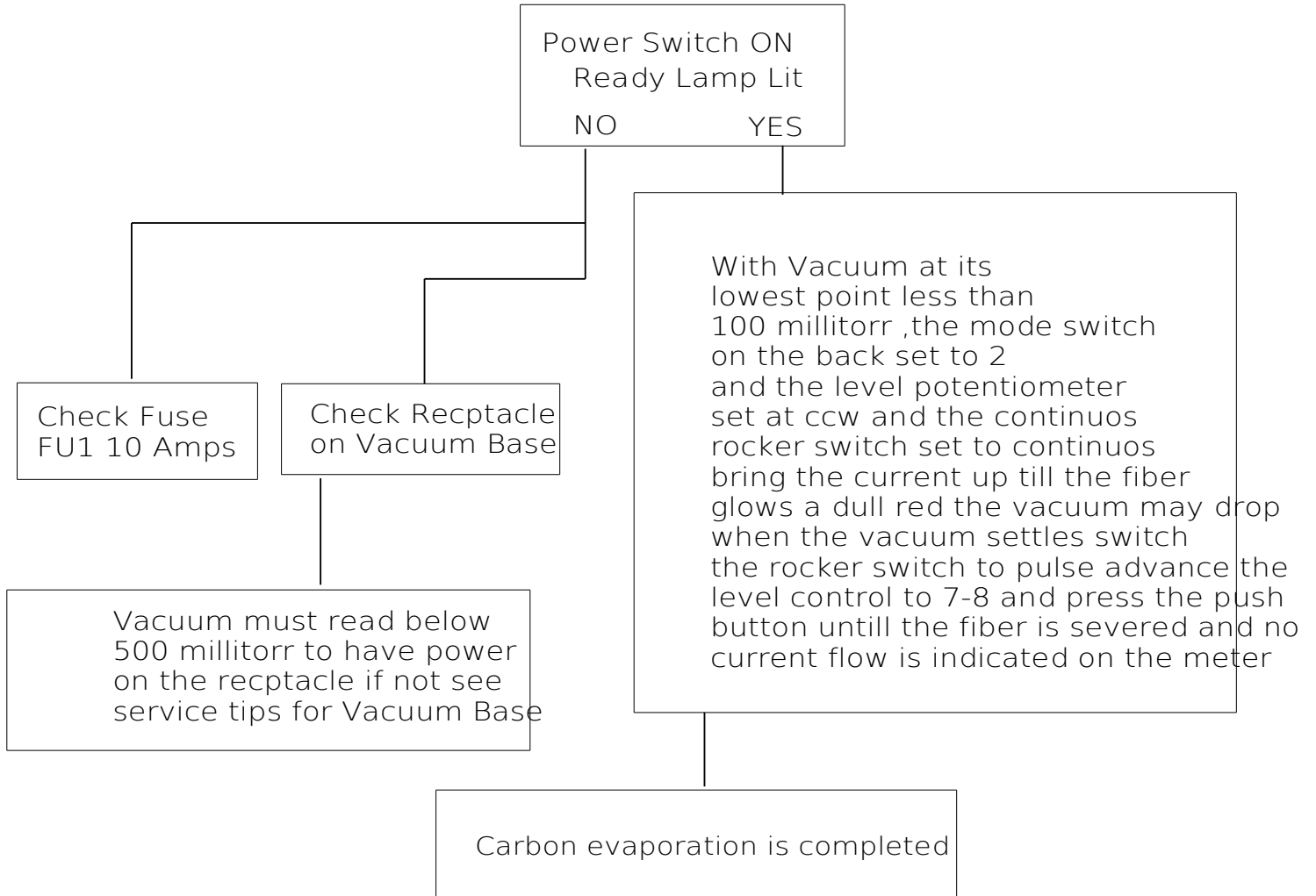

Date	REV NO	DESCRIPTION
	1	ADD FL 1/SHOW 220VXFMR CONN
4/11/05	2	changed wiring to agree with new proportional control
4/27/05	3	Changed terminal # for C19A/1 and other notes on pot
1/11/08	4	changed to digital meter

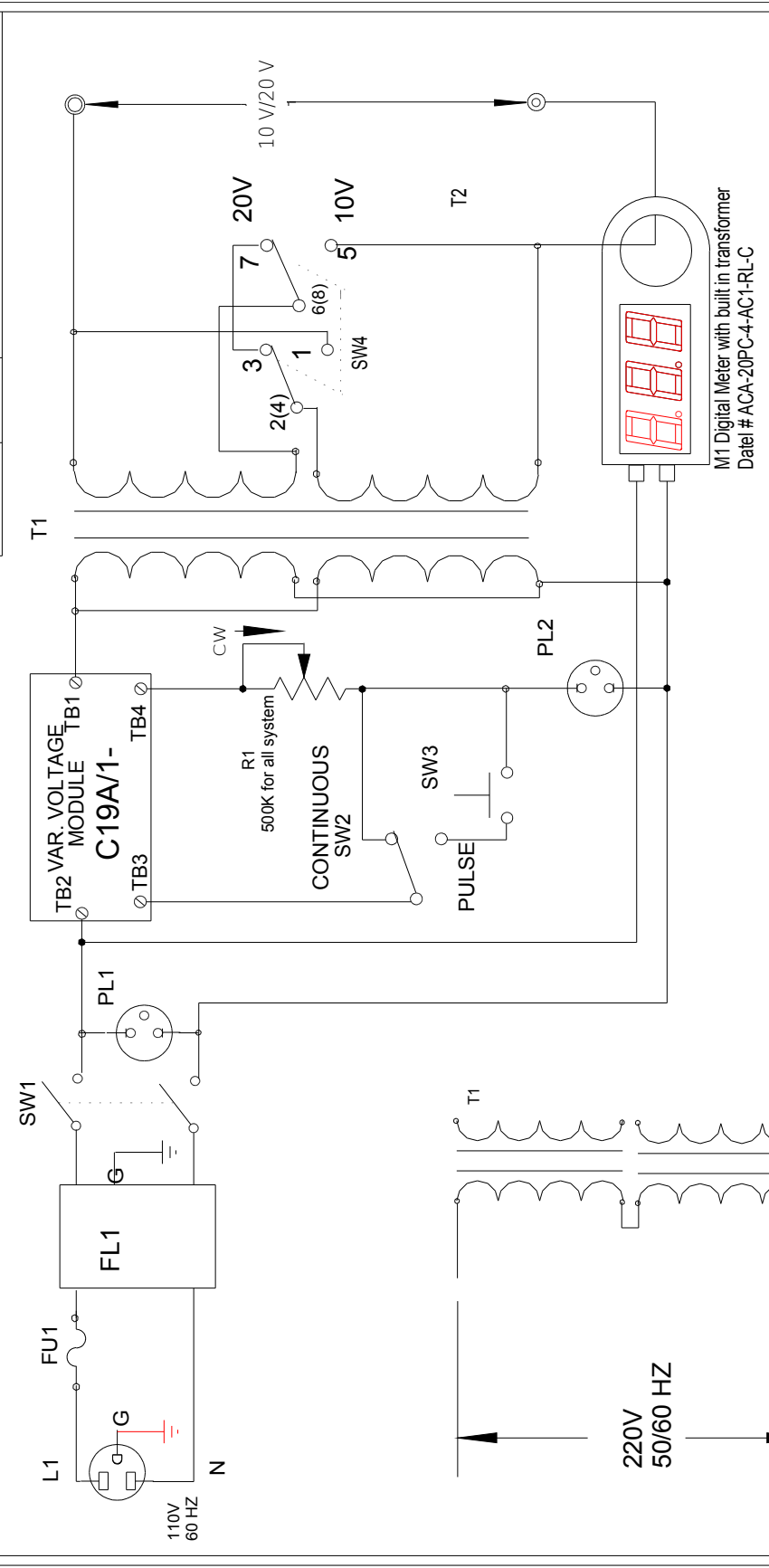

DWG.NO. ELEC 1
DESC. SCHEMATIC FOR CARBON MODULE
DATE 9/25/95 DRAWN BY ALM REV. NO. 4

File: CARBELEC.CAD

XFMR PRIM. CONNECTIONS FOR 220V VERSION

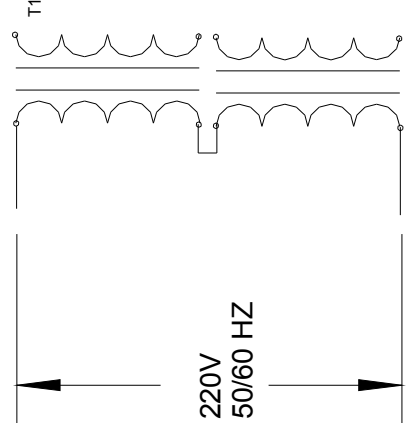

To arm of Cont.
Pulse switch

To voltage control pot

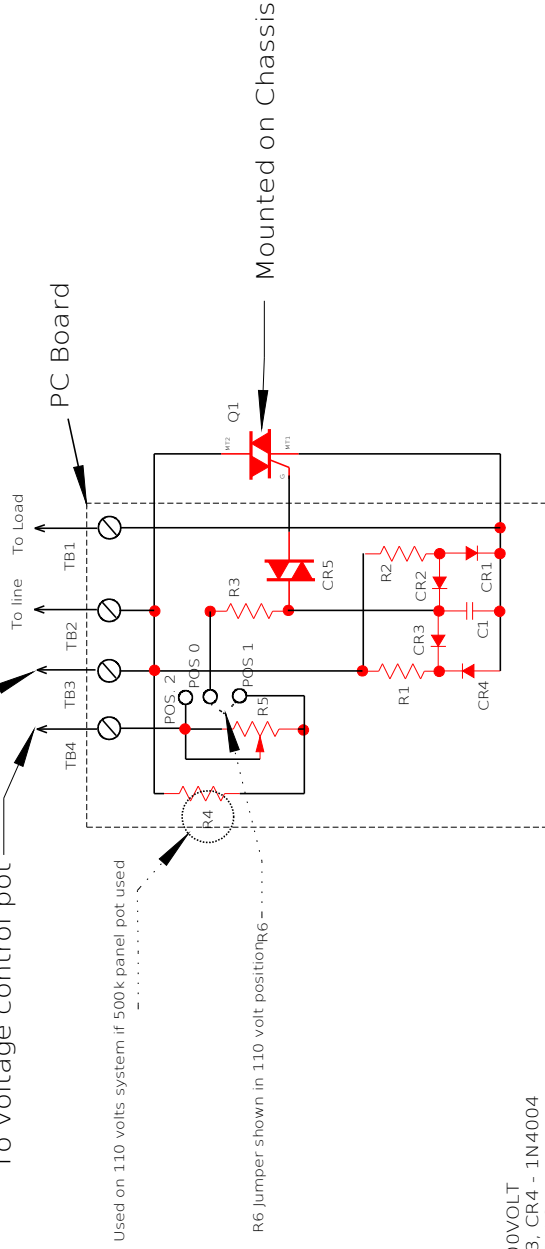

Used on 110 volts system if 500k panel pot used

R6 Jumper shown in 110 volt position

- R1, R2 - 15 K
- R3 - 3.3K
- R4 - 270 K
- R5 - 500K
- R6 - JUMPER
- C1 - .1MFD 400VOLT
- CR1, CR2, CR3, CR4 - 1N4004
- CR5 - HT32A DIAC
- Q1 - Q6025L6 TECCOR ALTERNISTOR

File: prpctrl.cad

Updated 6/22/05

C19A/1

DWG.NO.

New Proportional Controller

DESC

5/19/05 ALM

DATE

DRAWN BY

REV. NO.



**SPI-MODULE
CARBON COATER**

Instruction Manual

SPI Supplies Division of STRUCTURE PROBE, INC.

569 East Gay Street, P.O. 656, West Chester, PA 19381-0656 (610) 436 5400 Fax: (610) 436-5755

E-Mail SPI2SPI@2SPI.com Website - <http://www.2spi.com>

CanadaBox 187, Postal Station "T", Toronto, Ontario, M6B 4A1 Canada (416) 787-9193 800-668-2028 Fax (416) 781-0249
SPI Supplies is a registered trademark of Structure Probe, Inc.

TABLE OF CONTENTS

A. GENERAL DESCRIPTION.....	1
B. INSTALLATION.....	2
C. COATING OF SPECIMENS.....	2
D. LOADING EVAPORATION SOURCES.....	3
E. SPARE PARTS LIST.....	4

INSTRUCTIONS FOR USE

A. GENERAL DESCRIPTION

The SPI-MODULE CARBON COATER has been designed as a high current power supply capable of evaporating either carbon rods or carbon fiber and, when used with the SPI-MODULE CONTROL unit, becomes a compact easy-to-use carbon evaporation system.

The cabinet contains the high current AC power supply and all control and monitoring equipment.

Two modes of operation are possible: MODE 1 using a carbon rod head as shown in Illustration No.1 which requires 10V @ 100A power supply and MODE 2 using a carbon fiber filament head as shown in Illustration No.2 which requires a 20V @ 50A power supply. The carbon fiber head is normally supplied with the module. The carbon rod head may be purchased as an option. A back panel mounted switch allows the selection of the appropriate mode power requirements.

The front panel arrangement as shown in Figure 1 contains the main power switch that controls power to the unit, a meter that measures evaporation current in amperes, the power control that will vary the voltage to the electrodes between 0-10 volts @ 100 amps in MODE 1 [for carbon rod evaporation] and between 0-20 volts @ 50 amps in MODE 2 [for carbon fiber evaporation], the three position rocker selector switch that depressed left, gives continuous power applied to the electrodes and depressed right, allows control of power to the electrodes via the pulse button and the center position being off.

The back panel, shown in Figure 2, contains all the electrical service connections. [The main power enters via cable and is fused with a 1x1-1/4" glass 10 A fuse]. **NOTE:** For protection purposes this power cord must be connected to the power outlet on the SPI-MODULE CONTROL unit [remove any other power supply plug already in this socket] **NOT** to a laboratory socket. Two high current terminals and the MODE CONTROL switch complete back panel fittings.

B. INSTALLATION

1. The unit consist of the following components packed separately:
 - I. SPI-CARBON COATER MODULE
 - II. CARBONFIBER EVAPORATION HEAD
 - III. GLASS WORK CHAMBER
 - IV. ONE PACKAGE OF CARBON FIBER 1M SPI #(11431-AB)
2. Unpack the SPI-MODULE CARBON COATER and place it in position on the right-hand side of the SPI-MODULE CONTROL unit. Place the glass chamber in the base plate and place it into "0" ring grove. Fit the EVAPORATION HEAD onto the glass chamber. Connect the two high current power cables to the two high current terminals on the back panel. Connect SPI-MODULE CARBON COATER main power cord into the outlet on the back panel of the SPI -MODULE CONTROL unit [see note in general description] .

The SPI-MODULE CARBON COATER system is now ready for use.

C. COATING OF SPECIMENS

1. CARBON FIBER EVAPORATION

Switch on 'POWER' to the SPI-MODULE CONTROL unit and allow the instrument to achieve the best vacuum possible. It is not necessary to use argon gas for evaporation, although a better vacuum may be obtained by flushing the system with argon.

Ensure that the ' VOLTAGE' control is set at '0' and the rocker switch is in the center 'OFF' position, then switch ON the SPIMODULE CARBON COATER 'POWER' switch. Select position 2 on the back panel-mounted 'MODE CONTROL' switch.

2. OUTGASSING

Prior evaporation, it is necessary to "outgass" the carbon to remove entrapped gas. Ensure that the SPI-MODULE CONTROL unit has achieved a reasonable vacuum [at least 100 mbar] , select the "CONT" position on the rocker switch **ATTENTION FOR 220 VOLT SYSTEMS SEE NOTES AT END OF PAGE** and gradually increase the voltage control until the fiber is glowing dull red in color. The vacuum will initially drop, and after a period of time it will regain the required vacuum [less than 100 mbar]. At this time select the "PULSE" position on the rocker switch. Turn the voltage control to 7 or 8 and depress and hold the pulse button until the carbon evaporation is complete. This is usually indicated by the severing of the fiber filament and current ceases to flow.

Immediately, after evaporation, turn 'VOLTAGE' control back to '0' and set rocker switch to center 'OFF'. Switch off 'POWER' on both the SPI-MODULE CARBON COATER and the SPI-MODULE CONTROL unit. Vent the system using the EVAPORATION HEAD valve mounted on the top plate.

3. USE OF OPTIONAL CARBON ROD HEAD

Carbon rods can be evaporated by first outgassing the chamber as described on page 2, section 2.

Select position 1 on the back panel-mounted 'Electrode Control' switch. Evaporation occurs by pulsing the pulse switch until the appropriate amount of carbon is deposited.

D. LOADING EVAPORATION SOURCES

1. CARBON FIBER

The carbon fiber 'EVAPORATION HEAD' has two clamps for holding the fiber. A piece of fiber is inserted between these clamps and the two screws locked up. Superfluous fiber can be trimmed off with scissors.

2. CARBON RODS

The carbon rods [6.2mm _ dia.] should be loaded so that the fixed rod terminates in a smooth flat face over the center line of the evaporation head [Figure 3]. The fine pointed spring-loaded carbon should be fitted so that it is touching the fixed rod and clamped so that maximum spring tension is applied [see Figure.3 for illustration] .

NOTE: Both EVAPORATION HEADS get 'extremely hot' during evaporation, and subsequent carbon reloading should only be attempted when the heads have cooled down.

220 Volt Systems Notes

Each system is tested with local power sources which may not be exactly as the clients location has. The system has been provided with a trim potentiometer to adjust the power control of the carbon module. The potentiometer marked R5 on the picture at fig A is the trim pot. It is located on the power control module internally on the right side wall of the module.

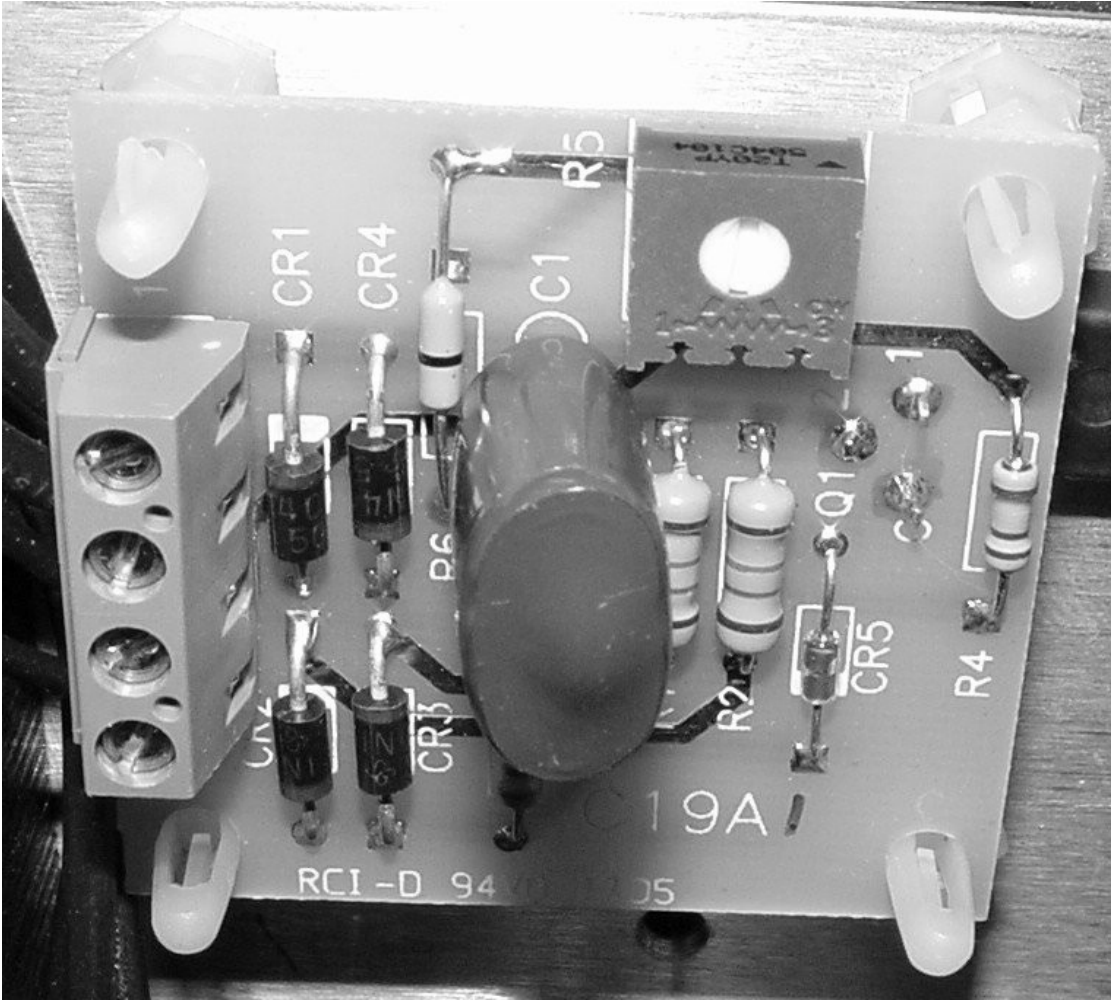

Fig A

List of Illustrations

- | | | |
|---|------|--|
| 1 | Fig1 | Front View of Carbon module on vacuum base |
| 2 | Fig2 | Rear View of Carbon module on vacuum base |
| 3 | Fig3 | Exploded View of Carbon Fiber Head |

If when going to out gas the filament lights up with the voltage control at "0" then it is appropriate to adjust the trim pot to turn off the current at the "0" position proceed as follows: first the top of the cabinet must be removed by taking out the 4 screws on the sides then lift the top up it will have a green wire attached but it is not necessary to remove it you will see the power control potentiometer on the right side and the trim pot on top. With the voltage control knob at 0 i.e. (fully counterclockwise) turn the trim pot fully counterclockwise there should be no current. Then turn the trim pot clockwise until there is a small current then turn the pot counterclockwise again until the current ceases this will be the right adjustment for the pot. Turn the power switch off and on again and then check to see if the voltage control at "0" is still with no current flow. Then the top of the cabinet can be replaced and run the system as described in the manual.

E. SPARE PARTS LIST FOR CARBON MODULE SPI#11428-AB

<u>CATALOG NO.</u>	<u>DESCRIPTION</u>
CV13/12	Fuse 10A 1-1/4"x 1/4" (1)
11458	Set of 2 o-rings for Pyrex Chamber
CM4/3	O-Ring for Vent Valve (1)
11428F-AB	Carbon Fiber Head
11439-AB	Carbon Rod Head
11431-AB	Carbon Fiber (1 meter)
01682-BA	Carbon Rods _" Pre sharpened 2_ " long, 3/16" neck (pk 10)
01799-AB	Carbon Rod Sharpener for 1/4"

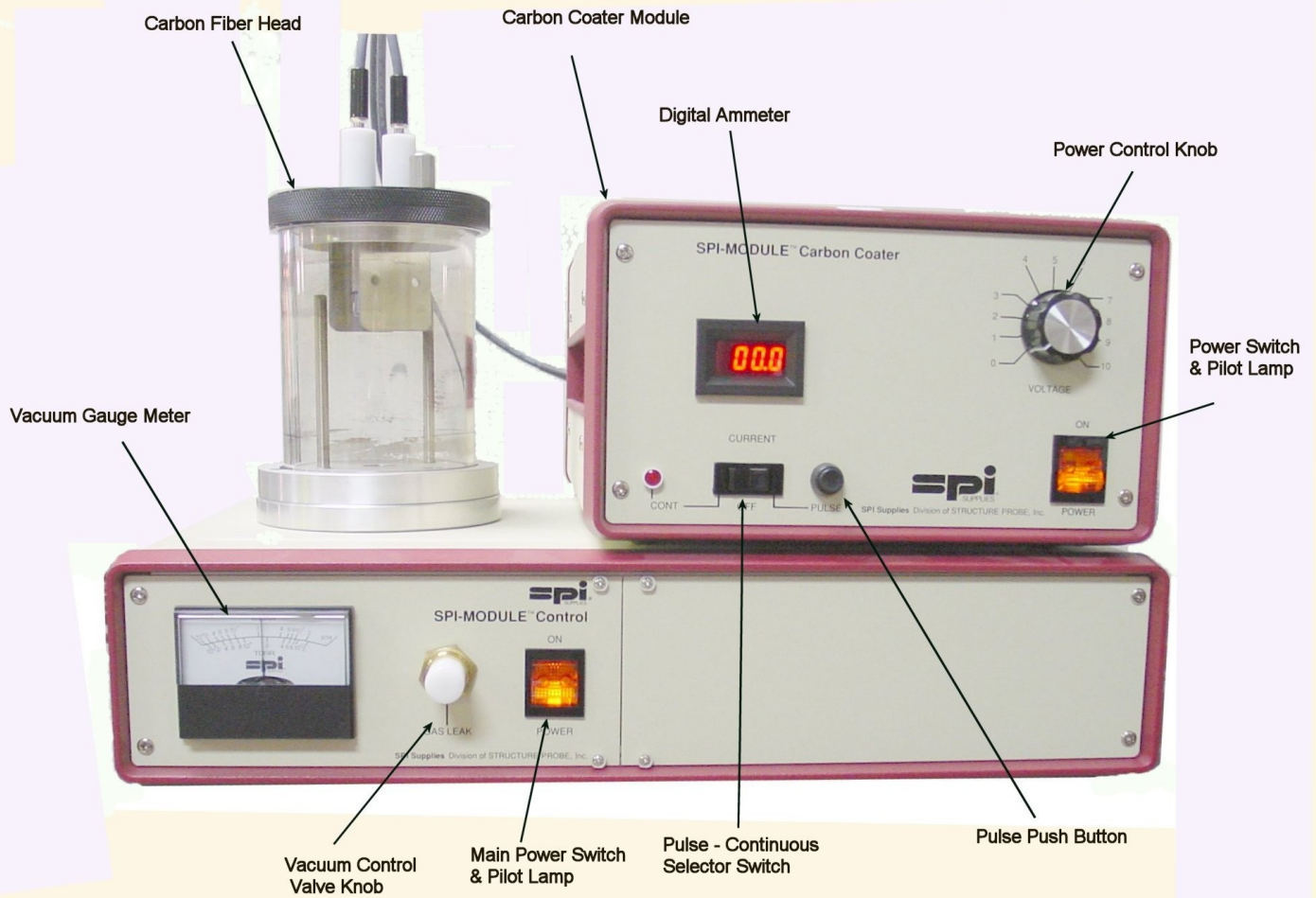
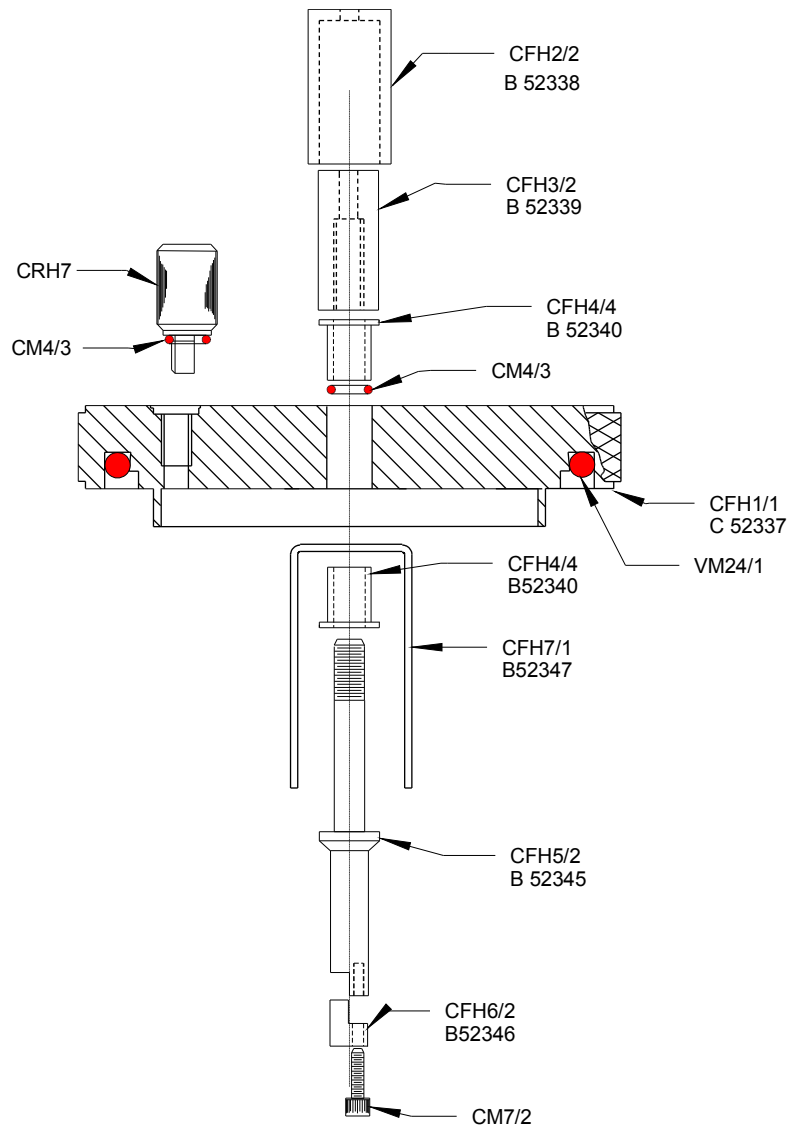

FIG 1



CARBON FIBRE HEAD ASSEMBLY

Fig 3

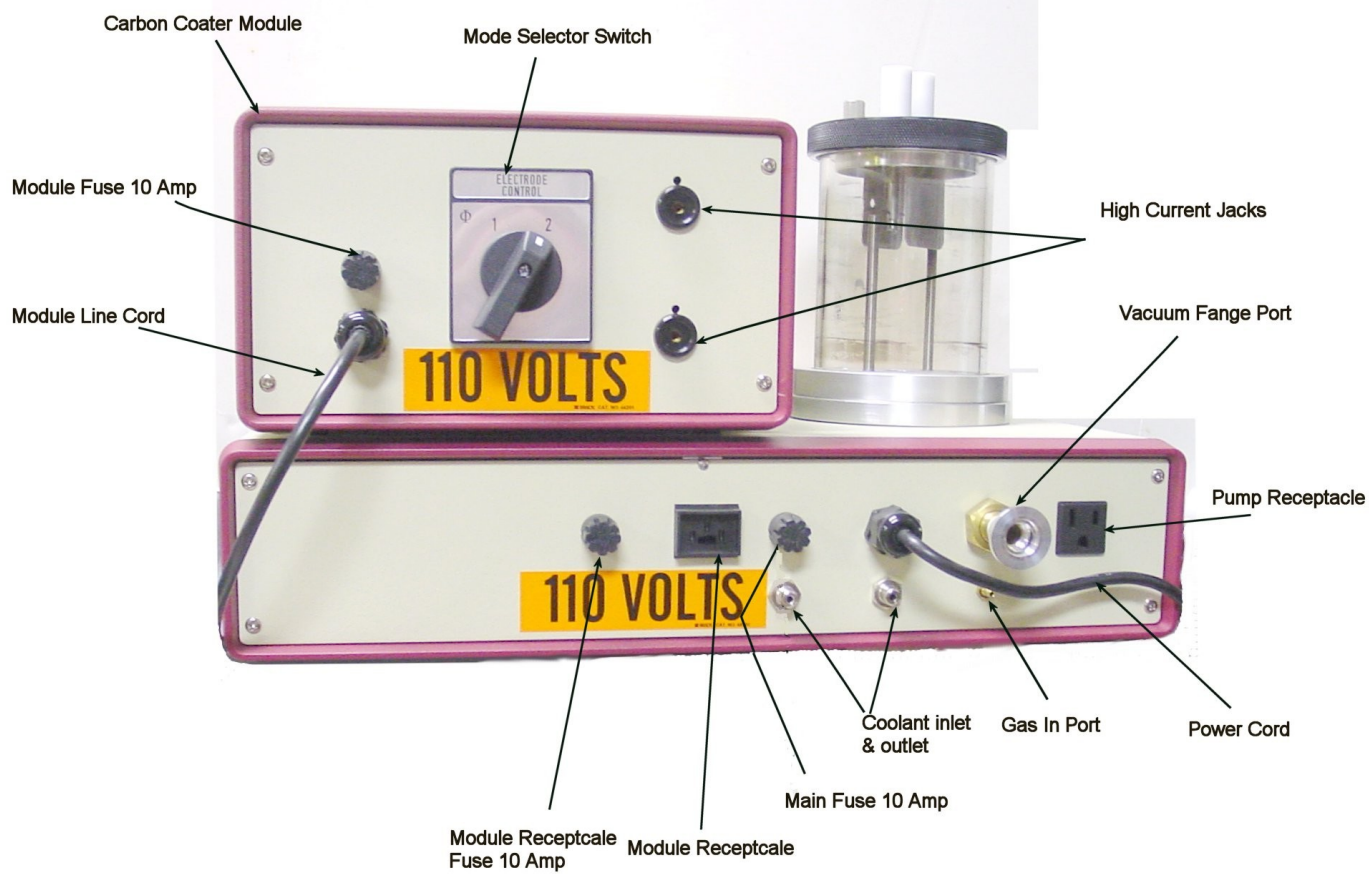

FIG 2